

BRACKET FEET

Bracket feet have just the right combination of strength and elegance. The thick blocks provide plenty of support for a project like the blanket chest in *Woodsmith* No. 145. But the graceful contours of the faces and the curves of the scalloped profiles keep the feet from looking too heavy. All in all, they're pretty impressive.

On the other hand, if you've never made bracket feet, it's easy to be a bit intimidated by all these curves. Don't be. They don't require nearly as much handwork as you might expect — most of the shaping is done at the table saw and band saw.

FROM ROUGH TO READY. Bracket feet start out as 1½"-thick blanks. But as you can see in the margin, I glue two ¾"-thick pieces together, so I don't have to buy 1½"-thick stock. The blanks are then cut oversized (4½" x 16"), so the two halves of each foot can be cut from one blank.

All of the work of shaping the face profile is done while the blanks are oversized. Then they'll be cut in half and mitered, and the curved scallop will be cut (see the pattern on the next page). Finally the halves of each front foot will be glued together.



▲ Bracket feet look like they were cut from thick blocks of wood, but these blanks were made with two pieces of ¾"-thick stock.



Roughing Out the Face Profile

With the blanks in hand, you're ready to create the S-shaped profile on the face of each blank. All the rough work for this is done at the table saw, starting with a simple cove (Steps 1-3).

COVE SET-UP. A cove is cut by pushing a board across the table saw at an angle, guided by a pair of wood fences. If you've never cut a cove before, don't worry. Steps 1 and 2 will show you exactly how to set up

your table saw. And cutting the cove is done in multiple passes, "nibbling" away only 1/16" of material with each pass (Step 3).

To find the correct angle of the fences, I first mark the entry and exit points of the blade when it's raised to its full height, which is 5/8" for this cove (Step 1). Then I make a posterboard "frame" (with a 1¾"-wide opening and a ¾" border) and

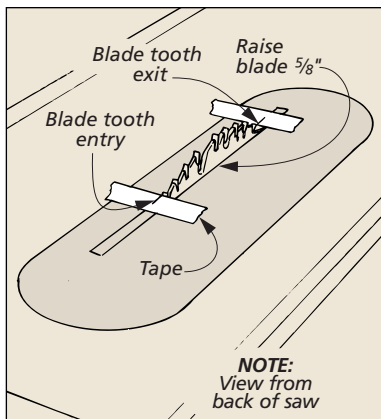

1 To begin, raise the blade to the final depth of the cove (5/8"). Then using tape, mark where the teeth of the blade enter and exit the table.

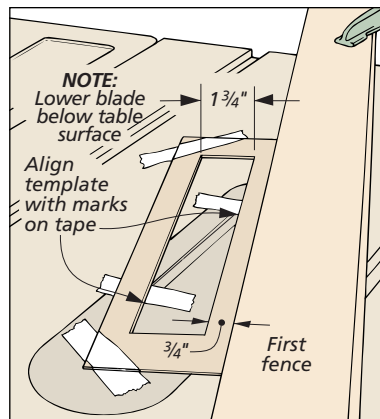

2 Next, make a template with a 1¾" inside window (the cove's final width). Then angle the template so the long edges touch the marks.

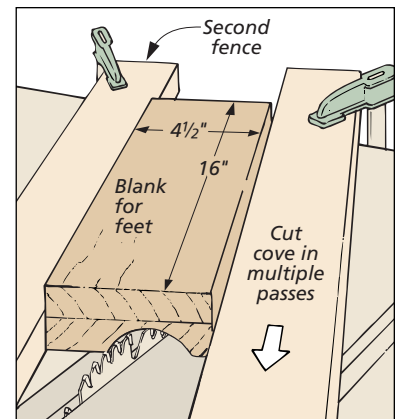

3 With both fences in place, set the blade 1/16" high and make a pass. Raise blade in 1/16" increments and repeat until cove is 5/8" deep.

angle it until it touches the entry and exit points (Step 2). Now the first fence can be clamped in place.

To position the second fence, simply clamp it to the table with one of the blanks sandwiched in between. (The blank should slide smoothly.)

CUT COVE. At this point, you're ready to cut the coves (Step 3). Start with the blade set $\frac{1}{16}$ " above the table, and don't remove any more than $\frac{1}{16}$ " in one pass. Stop when the cove is at its full height ($\frac{5}{8}$ ").

MAKE TEMPLATE. Now before you do any more shaping, it's a good idea to make a template. (As you can see in the photo below, I made mine out of hardboard.) The pattern below is the only one you need for the feet. The curve on the end will help you create the face profile. (The scalloped profile will be cut later.)

With your template in hand, set it on the ends of each blank and align it with the cove. Then trace around the template, as shown in the photo below. Now you've got a good guide for what the profile will look like and where to remove the waste.

FINISHED WIDTH. The next step is to begin removing the waste by trimming the edges of the blanks (Step 4). With the profile already drawn on the ends, all you need to do is set the fence so the blade aligns with the profile lines. (You'll end up trimming about $\frac{1}{4}$ " or so from each edge.)

COMPLETE COVE. Now you're ready to elongate one edge of the cove. You could do this with a rasp or a file, but I removed most of the waste much quicker with a $\frac{1}{2}$ "-wide stacked dado set, as you can see in Step 5.

To remove the waste, you'll need

to adjust both the angle and the height of the blade, but there aren't any hard and fast dimensions to work with here. The best way to set up the saw is to crouch behind the saw and eye down the saw blade (with the blank behind the blade so you can see the profile.)

Don't attempt to cut right to the line. The idea is just to get close enough so the final shaping doesn't take a lot of time (or effort). And be ready to make several passes, resetting the fence and the angle of the blade with each pass.

ROUND-OVER. After the cove is completed, the roundover located on the top, outside corner can be roughed out. Again I used the table saw to remove much of the waste, but this time, I used a regular saw blade tilted 45° , as shown in Step 6.

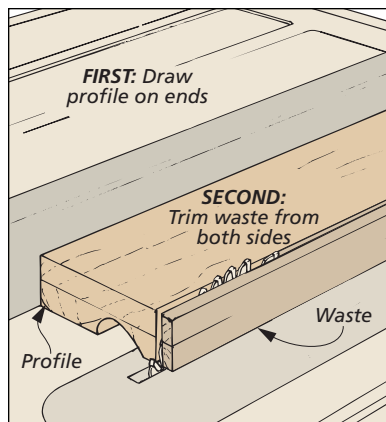

4 With the profile laid out on the ends of each blank (see photo below), rip them to final width (4"), trimming waste from each edge.

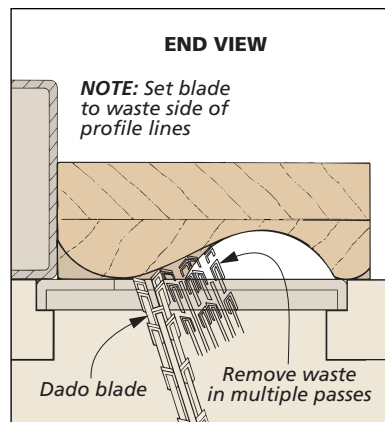

5 Next, extend shape of cove by removing waste with dado blade set at angle. Adjust rip fence and dado blade between passes as needed.

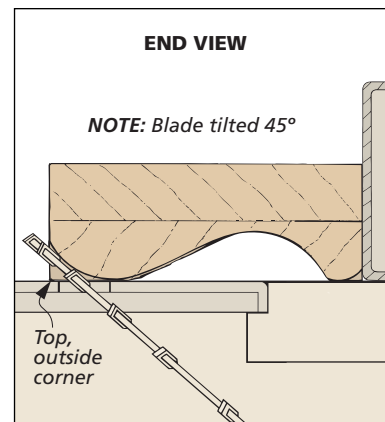

6 Now the top, outside corner of each blank can be trimmed. To do this, tilt a regular saw blade 45° . Then sneak up on the final layout line.

Bracket Foot Pattern

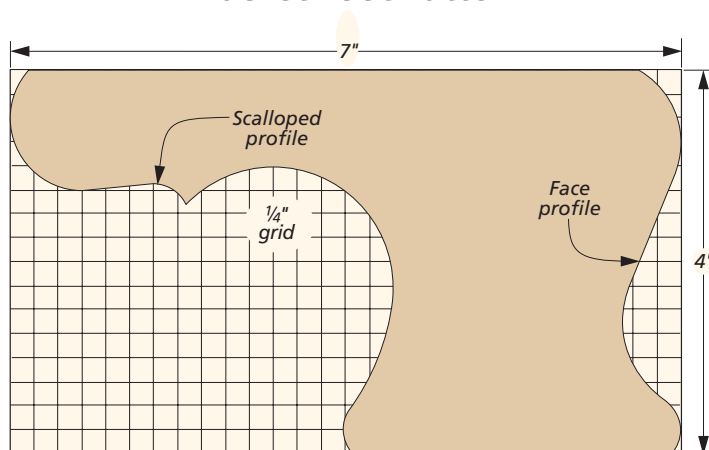

NOTE: Enlarge this pattern 200% for a full size pattern



▲ Hardboard makes a good, reusable template for the bracket feet profiles, see pattern at left. To position the template on the blank, just line it up with the cove you've already cut.

Face Profile: Clean-Up

Up to this point, all the work at the table saw has been to get the face of the blanks to rough shape. Now it's time to clean up all the unwanted shoulder lines and saw marks left by the saw blade so that you end up with a smooth curve on the face profile.

This is where the handwork of making bracket feet comes in, and you'll find there's really not much to it. Each blank only has a little material left to remove, and the profiles drawn on the ends will guide you. But don't be too critical. The bracket feet end up far enough apart so that no one will notice if the profiles aren't exactly identical.

OUTSIDE CURVES. The areas that need the most shaping are the outside (convex) curves at the top and bottom of the feet. I shaped them with a block plane set to take a thin shaving, as shown in Step 7. (But

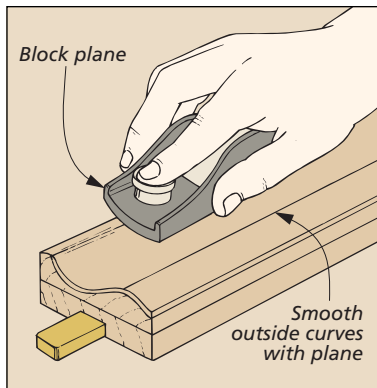

7 On the blank's outside curves, plane any hard lines, removing enough waste to create a gentle curve that matches the layout on the ends.

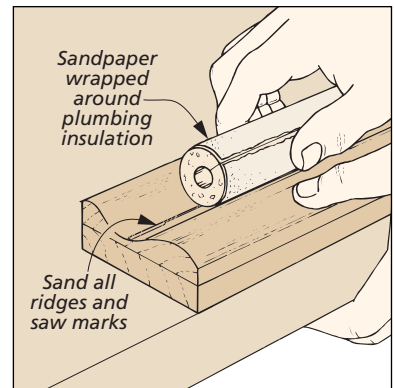

8 Once the ridges have been planed away, smooth out the curve using a piece of sandpaper wrapped around a short length of plumbing insulation.

you can also get the job done with a rasp or a Surform-type plane, which looks like a block plane but works like a rasp.) Start by smoothing out the noticeable shoulders. Then simply keep taking thin shavings, following the profile drawn on the end.

INSIDE CURVES. The inside curves are even easier. All you need to do is sand or scrape them (Step 8). I wrapped sandpaper around a length of plumbing insulation. It provides just enough support *and* flexibility to sand the curve efficiently.

Miter & Spline Joint

Now that the profile of each blank is complete, they can be cut into individual pieces and one end of each front foot piece can be mitered.

LABEL BLANKS. But before you get started, it's a good idea to label the pieces, as shown in the drawing below. For each front foot, you want to glue the ends you cut apart back together — this time joining them with splined miters.

There are two reasons for doing it this way. For one thing, the grain on the faces of the halves will match up and “wrap around” the foot. Plus,

since you have already done the final shaping, this technique will ensure the profile of the pieces match as closely as possible. (You may still need to do some light sanding after they're glued together.)

MITER FRONT PIECES. With the parts labeled and cut apart, the next step is to miter one end of each front foot piece, as shown in Step 9. The nice thing here is you don't have to worry about an exact length. That will be taken care of when you create the scallop profile later. But I still added a stop block to the auxiliary

miter gauge fence so the piece wouldn't shift as it was being pushed across the blade.

After mitering the pieces, I lowered the blade and repositioned the stop block to cut a kerf for a spline (Step 10). These splines are added mostly to keep the pieces aligned when you glue them together.

BACK FEET. Because a project like the blanket chest is usually against a bed or wall, only the front feet are mitered. The back feet are simply supported with a small triangular brace in back (refer to Step 17).

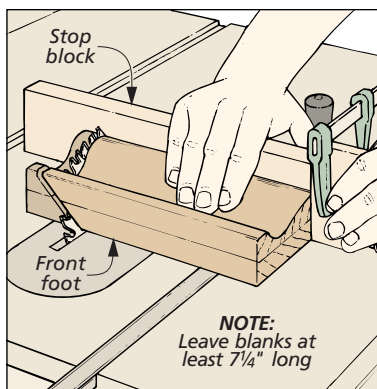
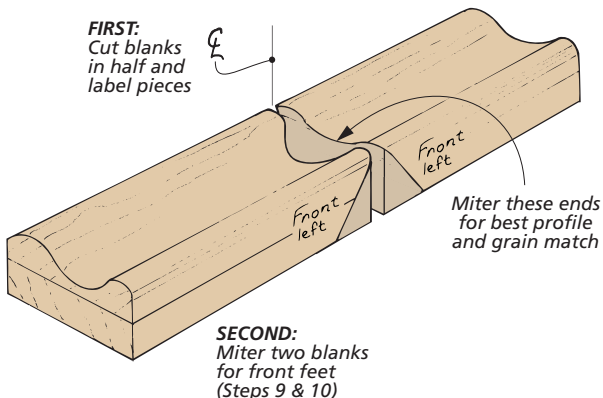

9 With the profile complete, cut all the blanks in half. (See drawing at left.) Then miter the four pieces that will be used for the front feet.

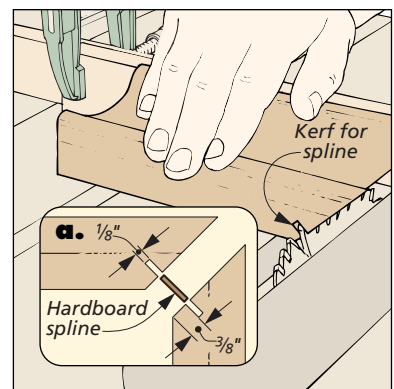

10 Now cut a $\frac{3}{8}$ "-deep kerf in each mitered end for a spline to help align the pieces. Then cut a $\frac{1}{8}$ " hardboard spline to fit in the kerf.

Scalloped Profile

Before you can glue the feet together, there's still one more profile to cut. It's cut on the end of the blank (instead of on the face), and the work is done at the band saw and drill press (instead of the table saw). But the first thing to do is lay out the profile.

LAY OUT PROFILES. You've already made the template for this curve, refer to the pattern on page 2. But this time, the front and back legs are slightly different. The front feet are 7" long overall (Step 11), while the back feet are only 6½" (Step 12). For both feet, I laid out a line across the back side of each blank and then aligned the template with this line.

With the back feet, the thing to keep in mind is that they're *not* identical. With their contoured faces, they're mirrored images of each other, so make sure you end up with both a right and a left back foot.

SHAPE PROFILE. These profiles are easier to create than the face profiles. I roughed out the profile at the band saw (Step 13). Then I sanded as much as possible with a drum sander (Step 14) before finishing them with a little hand sanding.

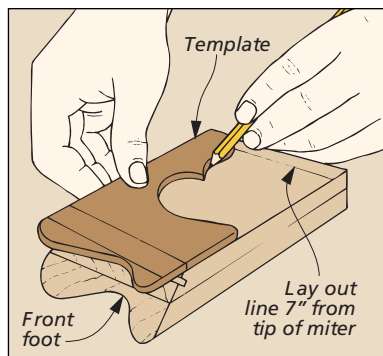

11 Transfer scalloped part of the pattern onto back side of the mitered pieces. Position the template so the feet will end up 7" long.

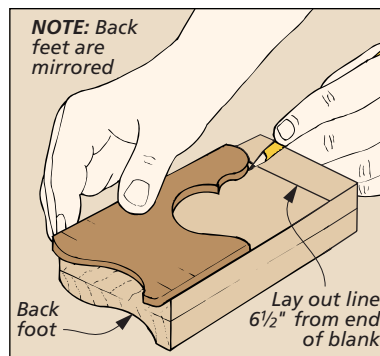

12 Lay out scallop on each back foot blank so it will end up 6½" long. Flip template for second foot so back pieces are mirrored.

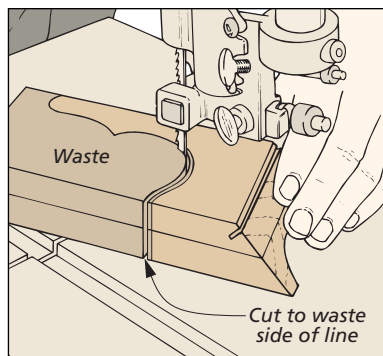

13 Cut out scalloped shape on both the front and back feet using the band saw, staying to the waste side of the layout line.

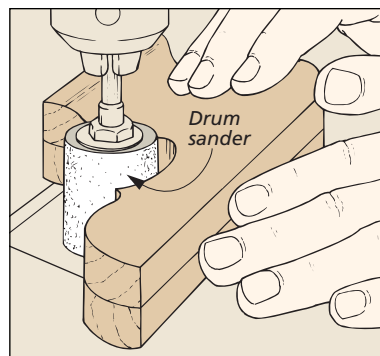

14 To complete the shaping of each foot, sand the scalloped profile to the layout lines, using a drum sander in the drill press.

Foot Assembly

Now that the profiles are complete, the feet are ready to be assembled.

FRONT FEET. To join the halves of the front feet, I wanted to use clamps, but there's no good place to position them. So I glued small clamping blocks to the top and bottom edges parallel with the mitered end. And to

make sure I could remove them easily, I used plywood for the blocks and liquid hide glue to attach them, as shown in the margin photo. The plywood can be split fairly easily between the bottom two plies, and then by applying a little hot water to the plywood, you can loosen the

bond of the hide glue. Then the foot can be scraped clean, and the spline can be trimmed flush.

BACK FEET. To provide plenty of support for the back feet, I cut small triangular braces and glued and screwed them to the back of the feet, as shown in Step 17 below. **W**

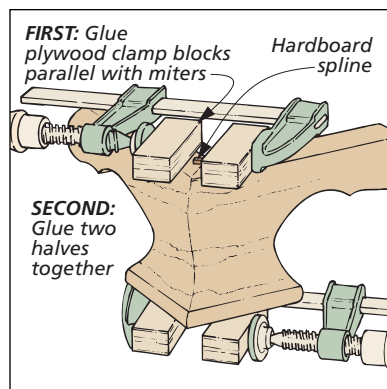

15 Using hide glue, attach clamping blocks to the pieces parallel to the mitered ends (see margin). Then glue halves together.

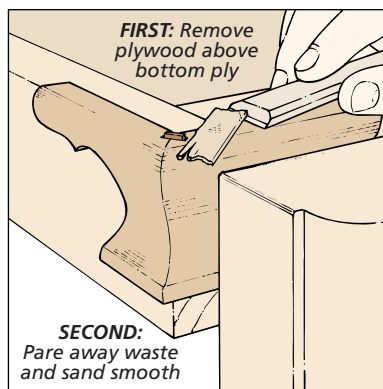

16 To remove clamping blocks, pry away at bottom ply. Then loosen glue with hot water, pare away ply with chisel, and sand smooth.

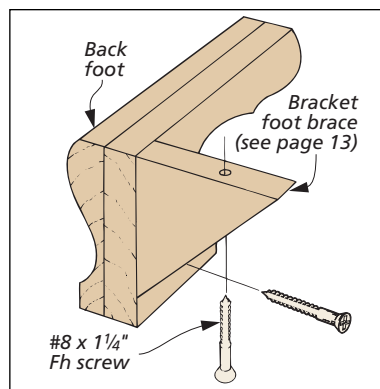

17 For back foot, make a brace and drill counterbored shank holes. (Use handscrew to hold brace.) Then glue and screw to foot.



▲ These clamping blocks are plywood so they'll split easily along the plies. And they're glued in place with hide glue, which can be loosened with a little hot water.

Bracket Foot Pattern

Woodsmith No.139 - Bedside Chest

No. 145 - Paneled Blanket Chest

Copyright 2003, August Home Publishing Company. All Rights Reserved.

