

Online Extras

low cherry Bookcase

optional change of face

With a different base and a few molding profile changes you can give your low cherry bookcase an entirely new appearance. It won't take any additional work but you'll notice a more traditional look.

You can build the carcass, face frames, and side frames as shown in the article. Then add some cove molding changes to the top, base and side panels. Since a few of the dimensions have minor changes to reflect the new look, be sure to review the sizes of the aprons, moldings, and edging pieces before you begin work.

TOP EDGING. The top is built as described in the article. But to change the appearance I added a bullnose to the *front edging* (W) and *side edging* (X) pieces. I made

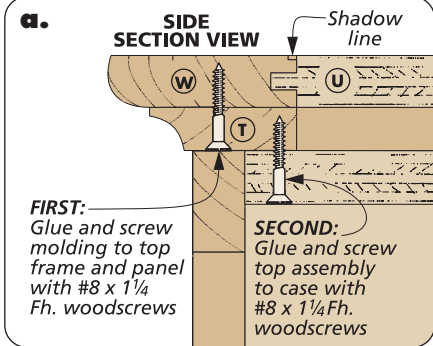
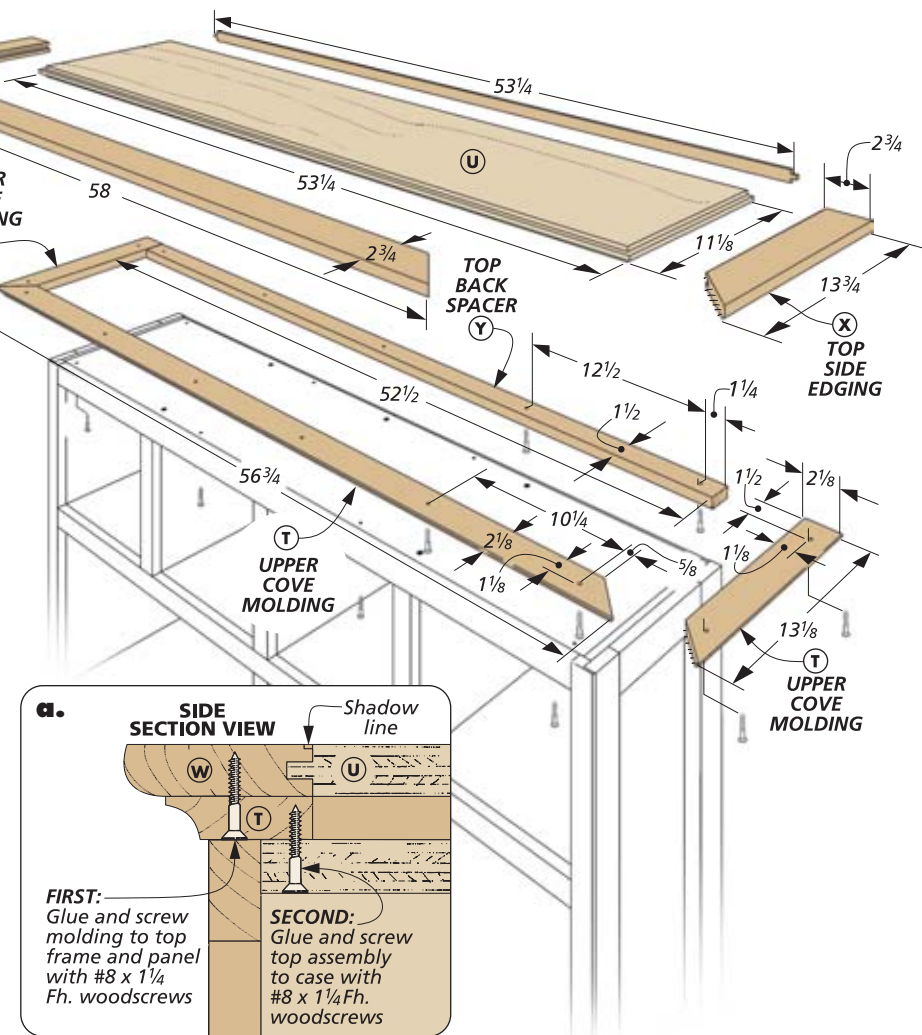

the bullnose on the router table. The technique I used is shown in the first two boxes below.

Since you'll be using the same edging for the bottom of the bookcase, it's a good time to cut enough edging for both the top and bottom and then add the bullnose treatments to each piece.

COVE MOLDING. I next made *cove molding* (T) for the top and base treatments to substitute for the beveled molding in the original project. The third box below shows you how this is done.

SIDE PANELS. Instead of beveled molding around the side panels I used a narrow *cove molding* (N).

How-To: Make A Bullnose & Cove Moldings

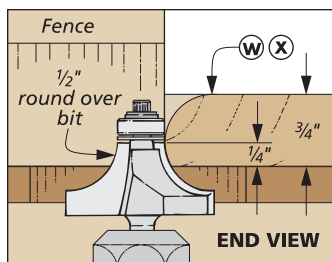

Bullnose Top. Just mount a $\frac{1}{2}$ " round over bit in the router table $\frac{1}{4}$ " above the table and rout the top edge of the workpiece.

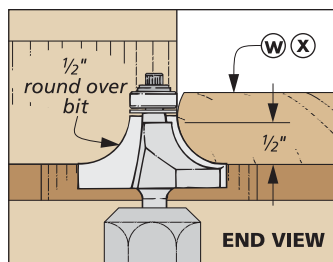

Bullnose Bottom. Next set the round over bit $\frac{1}{2}$ " above the table. Then turn the workpiece over and rout the bottom edge.

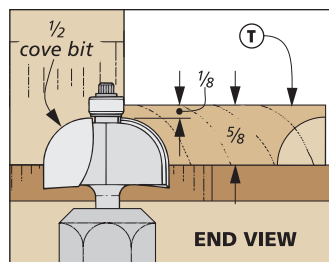

Cove Molding. Just mount your $\frac{1}{2}$ " cove bit to sit $\frac{5}{8}$ " above the router table and rout a cove along the side of the workpiece.

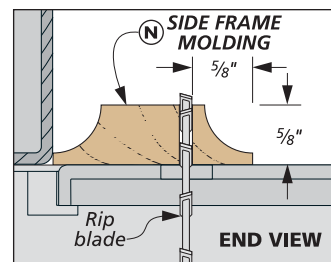

Narrow Cove Molding. Rout a cove along each side of a wide workpiece and then cut to the desired width on your table saw.

You can see how this narrow cove molding was made using the router and table saw in the last box on the previous page. The molding is then glued inside the side frame.

TOP ASSEMBLY. One of the things you'll find different from the original project description is the way in which the top and bottom of the bookcase are assembled and screwed together. Let's take a look at the top assembly first.

The top is assembled in two steps, as shown in detail 'a' on the previous page. This allows for an easy and secure assembly of the top components of the bookcase.

The first step is to add glue and then screw the cove molding to the bullnosed front and side edging from the bottom. Next you'll want to screw the top assembly to the carcass from below, as shown in detail 'a' on the previous page.

BASE APRON PROFILE. I added a new profile to the base front apron (P). Enlarging the template at the bottom of the page 200% will give you a full size pattern of this new profile. I used my jig saw to cut this profile in the front apron. Then base front and side pieces are put together as described in the article.

BASE ASSEMBLY. The base of the bookcase is assembled in three steps as shown in detail 'a' at the right. Again this allows easy assembly and a secure fit.

You'll first want to screw the cove molding to the bottom edging

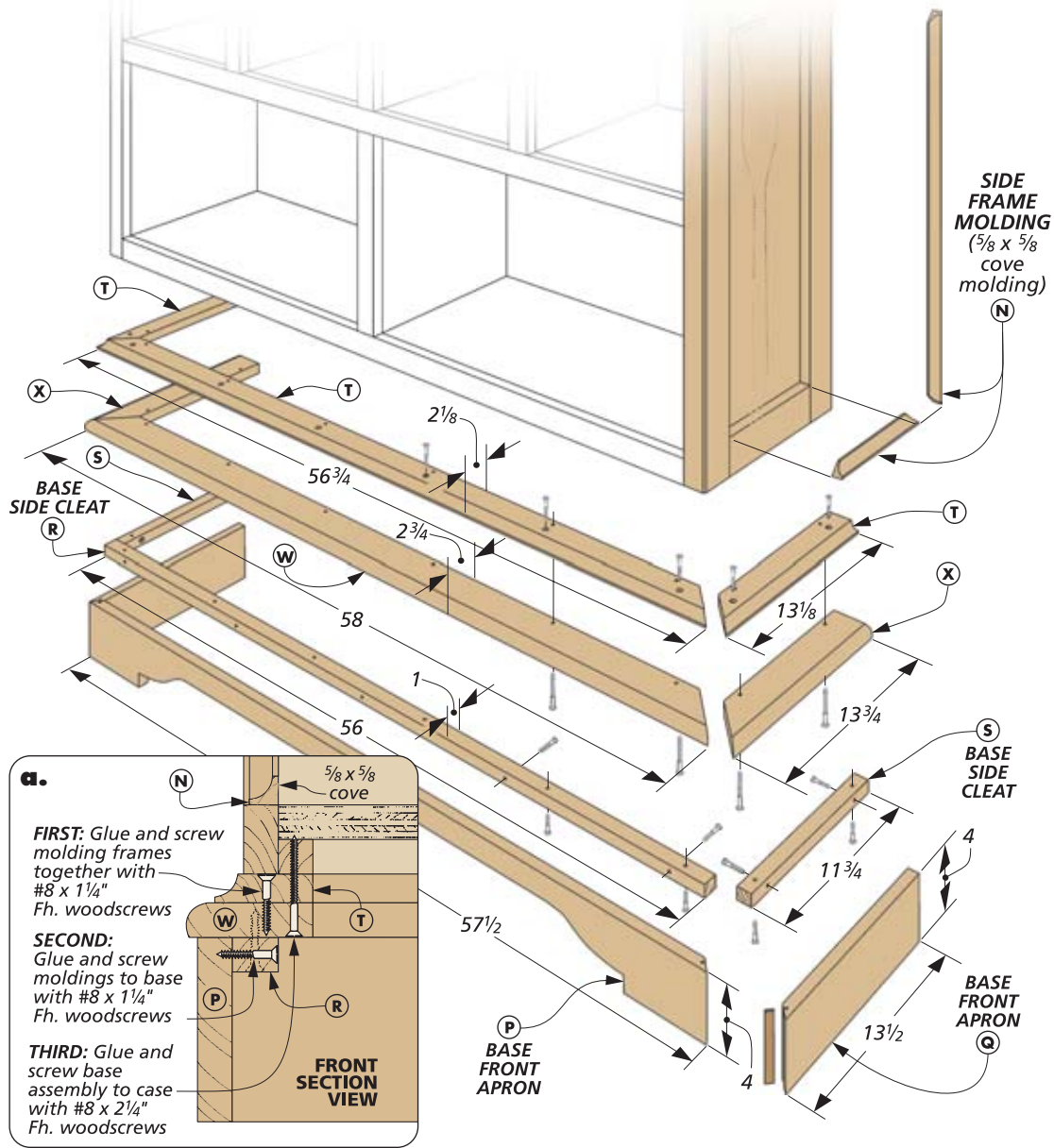

pieces. Next screw the base cleat to the apron and bottom pieces. And finally, use screws to secure the bottom edging through the cove molding and into the front filler

already attached to the carcass.

With the base securely fastened to the carcass, all that's left to do is to cut the back panels to size and screw them in place. **W**

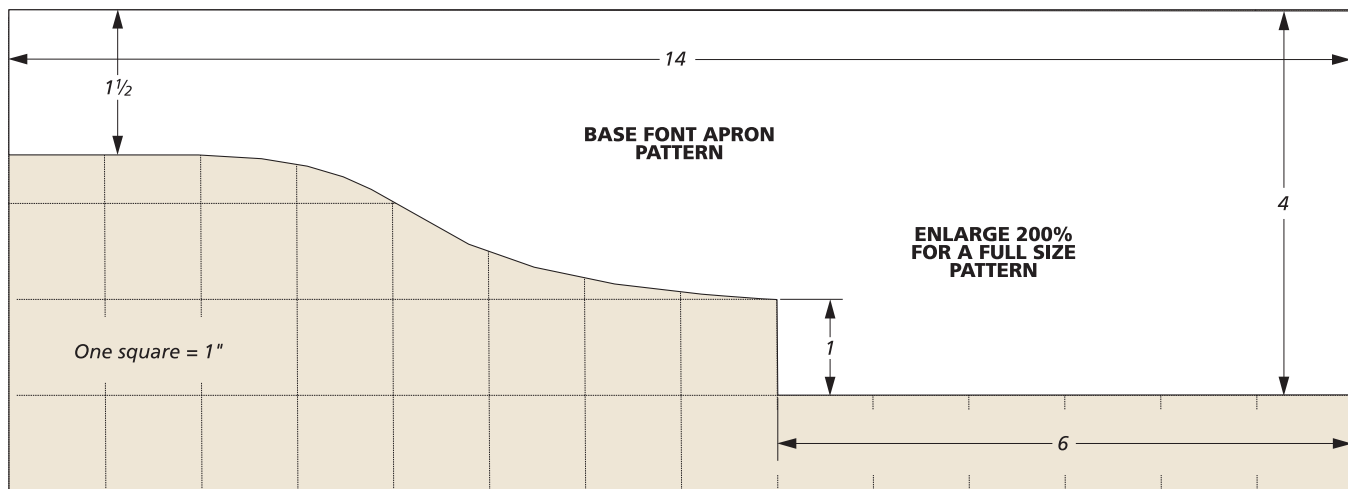

Materials, Supplies, & Cutting Diagram No. 155

A Case Top/Bottom (2)	$\frac{3}{4}$ ply. - 11 1/2 x 53	R Base Front Cleat (1)	$\frac{3}{4}$ x 1 - 56
B Case Sides (2)	$\frac{3}{4}$ ply. - 11 1/2 x 27 1/2	S Base Side Cleat (2)	$\frac{3}{4}$ x 1 - 11 3/4
C Case Center Dividers (2)	$\frac{3}{4}$ ply. - 11 1/2 x 25 3/4	T Upper/Lower Cove Molding (2)	$\frac{5}{8}$ x 2 1/8 - 86 rgh.
D Case Upper Dividers (4)	$\frac{3}{4}$ ply. - 11 1/2 x 11 1/4	U Top Panel (1)	$\frac{3}{4}$ ply. - 11 1/8 x 53 1/4
E Case Horizontal Dividers (2)	$\frac{3}{4}$ ply. - 11 1/2 x 26	V Top Panel Back Edging (1)	$\frac{1}{4}$ x $\frac{3}{4}$ - 53 1/4
F Case Front Filler (1)	$\frac{3}{4}$ x $\frac{3}{4}$ - 52 1/2	W Top/Bottom Front Edging (2)	$\frac{3}{4}$ x 2 3/4 - 58
G Face Frame End Stiles (2)	$\frac{3}{4}$ x 1 1/2 - 27 1/2	X Top/Bottom Side Edging (4)	$\frac{3}{4}$ x 2 3/4 - 13 3/4
H Face Frame Upper Stiles (3)	$\frac{3}{4}$ x 1 1/2 - 10	Y Top Back Spacer (1)	$\frac{3}{4}$ x 1 1/2 - 52 1/2
I Face Frame Lower Stile (1)	$\frac{3}{4}$ x 1 1/2 - 13	Z Back Panels (2)	$\frac{1}{4}$ ply. - 27 x 26 3/4
J Face Frame Rails (3)	$\frac{3}{4}$ x 1 1/2 - 52 1/2		
K Side Frame Front Stiles (2)	$\frac{3}{4}$ x 2 1/8 - 27 1/2	• (59) #8 x 1 1/4 Fh Woodscrew	
L Side Frame Back Stiles (2)	$\frac{3}{4}$ x 2 1/4 - 27 1/2	• (9) #8 x 11/2 Fh Woodscrew	
M Side Frame Rails (4)	$\frac{3}{4}$ x 2 1/4 - 8	• (10) #8 x 21/4 Fh Woodscrew	
N Side Frame Molding (1)	$\frac{5}{8}$ x $\frac{5}{8}$ - 127 rgh.	• (32) #6 x 3/4 Fh Woodscrew	
O Case Back Filler (1)	$\frac{3}{4}$ x $\frac{3}{4}$ - 54		
P Base Front Apron (1)	$\frac{3}{4}$ x 4 - 57 1/2		
Q Base Side Aprons (2)	$\frac{3}{4}$ x 4 - 13 1/2		

$\frac{3}{4}$ " x 5 1/2" - 72" Cherry (2.75 Bd. Ft.)



$\frac{3}{4}$ " x 5 1/2" - 72" Cherry (2.75 Bd. Ft.)

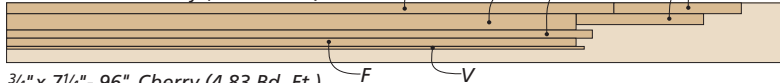

$\frac{3}{4}$ " x 7 1/4" - 96" Cherry (4.83 Bd. Ft.)



$\frac{3}{4}$ " x 7 1/4" - 96" Cherry (4.83 Bd. Ft.)



$\frac{3}{4}$ " x 7 1/4" - 96" Cherry (4.83 Bd. Ft.)



$\frac{3}{4}$ " - 48" x 96" Cherry Plywood

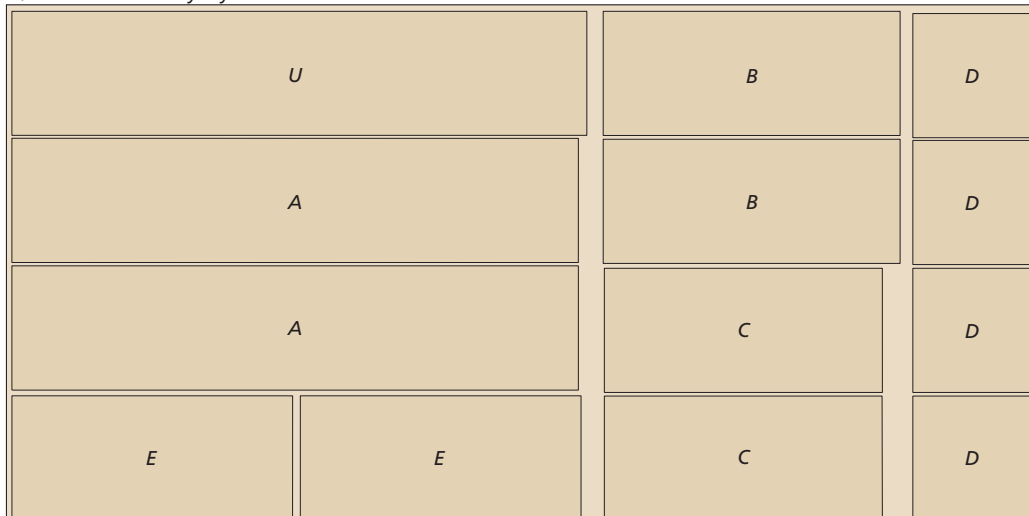

ALSO NEEDED: One - 48" x 96" sheet $\frac{1}{4}$ " Cherry plywood