



Online Extra

Pocket Hole Joinery

When you think of pocket hole joinery you probably associate it with mass-produced kitchen cabinets and furniture. The kind that are easy to build and fast to assemble.

But this type of joinery is not just for making face frames for cabinets. And you don't have to work in a cabinet shop to use it. Because it's so quick and easy (see box below), I find myself relying on it more and more.

Pocket hole joinery works well for almost any joint. Here are a few ways I've found to get the most out of it.

CORNER JOINTS. Pocket holes are great for joining corners, like attaching aprons to table legs. Pocket holes are faster and easier to use than cutting mortise and tenon joints. And with a little bit of reinforcement from a corner block, they're every bit as strong. You can see what I mean in the photo above.

Just use the jig to guide your drill and place two pocket holes at the end of each apron. Then choose the right pocket screw for the job (see the hardware box on the next page) and secure the apron to the leg.

How-To: Pocket Hole Basics

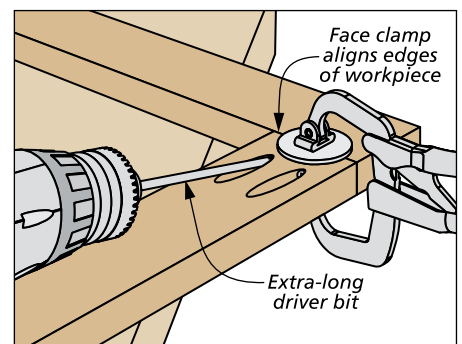
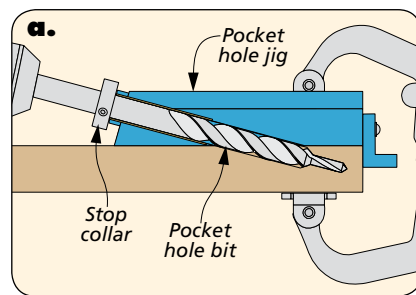
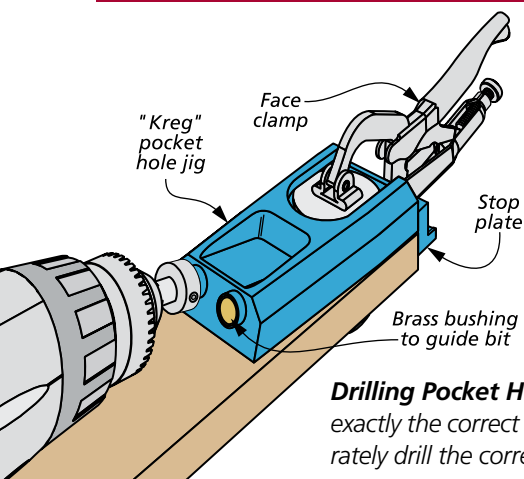

Drilling Pocket Holes. The pocket hole jig guides the drill bit at exactly the correct angle. The stop collar can easily be set to accurately drill the correct depth hole in various thicknesses of wood.

Inserting Pocket Hole Screws. After the hole has been drilled, it's easy to drive the self-tapping pocket hole screws in place.

JOINT REINFORCEMENT. As I mentioned, it doesn't hurt to reinforce table legs with a corner block as shown in the photo on the opposite page. It's attached with three pocket hole screws. One screw is driven into each apron and one into the leg. This adds even more strength and stability to the legs at each of the corners.

MITER JOINTS. Pocket hole joinery can come in real handy when you need to pull a miter joint together. To hold a miter joint tight, drill a pair of pocket holes opposite and perpendicular to the joint line, as shown in the photo at the right. A face clamp holds the joint flush while you drive in the screws.

ATTACH A TABLE TOP. You don't usually think of using pocket screws for attaching the top of a table. But it's as easy as drilling holes into the aprons (see photo below) and then driving screws into the table top. Using the jig and the correct screw size insures that the screws don't come through the top of the table.

If you're concerned about wood movement, drill the pilot holes in the edge a little oversized. Then after driving the screw,



▲ Two pocket holes square to the miter joint and opposite one another allows pocket hole screws to secure the joint. A face frame clamp makes it easy to hold the joint in position while the screws are inserted.

back it out one quarter turn so it can move as temperature or humidity changes.

SHELF EDGING. Adding shelf edging to plywood with pocket holes is another of my favorite applications. It beats gluing and clamping each piece of edging in place. Of course, the edging needs to be thick enough to receive the screw.

Simply drill pocket holes on the underside of the shelf along the edge like you see in the photo below, right. Then drive in the pocket hole screws to fasten the

shelf edging securely in place. You can add a bit of glue as well.

The right angle clamp shown in the photo helps out here. One arm fits into the pocket hole and the flat surface on the other arm holds the edging in place so you can drive in the pocket screws.

As you can see, pocket hole joinery has many uses. The joints are strong and they look great. You'll be surprised at how many uses you come up with in your own shop for this quick and easy joinery.



▲ Attach a table top by drilling pocket holes and driving screws. Drilling the pilot hole a bit larger and backing the screw out slightly, allows for wood movement.



▲ Pocket holes are a great way to secure edging to a shelf. A right-angle clamp holds the edging to the shelf while the screws are driven in place.

Hardware: Choose the Best Pocket Screw



▲ **Thread Type.** Fine threads (top) are used for hardwood and course threads are for softwoods and plywood.



▲ **Screw Length.** Screws are available in many sizes so you can match the screw length to the thickness of the workpieces.



▲ **Head Style.** Use washer head screws (top) for plywood and softwoods. Pan head screws (bottom) are for hardwoods.